

Medical Gas Outlets

Installation and Maintenance Manual



SQUIRE-COGSWELL COMPANY WAS FORMED IN 1916 AS A SUPPLIER OF RAILWAY AND FOUNDRY EQUIPMENT IN CHICAGO. IT CONTINUED ALONG THIS BUSINESS PATH UNTIL 1951 WHEN THE COMPANY WAS PURCHASED BY WALTER F. DEVEREUX. AT THAT TIME THE COMPANY BEGAN TO CONCENTRATE ITS EFFORTS ON A LINE OF NON-LUBRICATED AIR COMPRESSORS AND VACUUM PUMPS AND A NICHE WAS FOUND SERVICING THE PRINTING PRESS INDUSTRY. UTILIZING THIS EXPERTISE, THE COMPANY BEGAN TO SUPPLY CUSTOM PUMPING PACKAGES FOR A VARIETY OF APPLICATIONS AND IN THE EARLY 1950'S SQUIRE-COGSWELL SOLD ITS FIRST HOSPITAL VACUUM PUMP PACKAGE, THE CORNERSTONE OF TODAY'S BUSINESSES AND PRODUCT LINES.

IN 1962, MR. HERBERT SCHIFTER, MR. DEVEREAUX'S SON-IN-LAW TOOK OVER AS PRESIDENT. MR. SCHIFTER WAS THE ORIGINAL INVENTOR OF THE "DIAMOND ADAPTER" WHICH HE PATENTED IN 1959. THE BUSINESS GREW SIGNIFICANTLY AS A SUPPLIER OF CUSTOM DESIGNED AND CONSTRUCTED VACUUM AND AIR COMPRESSOR SYSTEMS FOR MEDICAL AND INDUSTRIAL USE. TO DATE, SQUIRE-COGSWELL HAS MANUFACTURED OVER 15,000 HOSPITAL AIR COMPRESSOR AND VACUUM PUMPING SYSTEMS THAT HAVE BEEN INSTALLED AROUND THE WORLD BEARING A VARIETY OF VERY WELL-KNOWN TRADE NAMES.

TODAY IN THE THIRD GENERATION OF FAMILY OWNERSHIP AND MANAGEMENT WITH CRAIG SCHIFTER AS CEO AND CAROL LEWIS AS PRESIDENT, SQUIRE-COGSWELL COMPANY CONTINUES TO SERVE THE WORLDWIDE NEEDS FOR HOSPITAL VACUUM PUMPING AND AIR COMPRESSOR PACKAGES ALONG WITH THE COMPLETE HEALTHCAIR® MEDICAL GAS PIPELINE OFFERING.

IN 1962, THE SUBSIDIARY COMPANY, AEROS INSTRUMENTS, INC., WAS FORMED TO MANUFACTURE SUCTION AND OXYGEN THERAPY EQUIPMENT FOR THE MEDICAL COMMUNITY. TODAY AEROS CONTINUES TO MANUFACTURE ALL OF THE SALES REQUIREMENTS FOR ONE OF THE LARGEST SUPPLIERS OF SUCH EQUIPMENT IN THE WORLD. AT THE SAME TIME, AEROS INSTRUMENTS PRODUCES AND SELLS ITS OWN LINE OF PORTABLE SUCTION MACHINES UNDER THE WELL-KNOWN NAMES OF MOBLVAC®, INSTAVAC®, CARE-E-VAC® AND TOTE-L-VAC®.

THE AEROS INSTRUMENTS SUBSIDIARY, WHICH IS AN ISO 13485 REGISTERED COMPANY AND IS A GOVERNMENT REGISTERED MEDICAL DEVICE MANUFACTURER, PRODUCES THE HEALTHCAIR® SERIES OF MEDICAL GAS PIPELINE EQUIPMENT INCLUDING THE MEDICAL GAS OUTLETS.

SQUIRE-COGSWELL/AEROS INSTRUMENTS INC. ARE THE ONE SOURCE FOR ALL MEDICAL GAS PUMPING, MEDICAL GAS PIPELINE EQUIPMENT AND MEDICAL ASPIRATION EQUIPMENT. FROM CUSTOM DESIGNED PUMPING SYSTEMS TO THE MOST MODERN LINE OF ASPIRATION EQUIPMENT AND MED GAS PIPELINE AVAILABLE ANYWHERE, SQUIRE-COGSWELL-AEROS DOES IT ALL. NO OTHER SUPPLIER SURPASSES OUR CONTINUITY OF EXPERIENCE AND LEADERSHIP IN THE MEDICAL GAS PUMPING, PIPELINE AND ASPIRATION MARKETS.

Table of Contents

□ Product Description	4
□ Dimensional Information	
Wall Outlet	5
Ceiling Outlet	6
Console Outlet	7
Ceiling Column Outlet	8
□ Complete Outlet Assembly Part Numbers	9
□ “Latch-Valve Mechanism” & “Back-Body Assembly” Part Numbers	10
□ Installation & Service Notes	11
□ D.I.S.S. Outlets	
Latch-valve Service Instructions	12
Latch-valve Replacement Parts	13
□ Ohmeda Compatible Outlets	
Latch-valve Service Instructions	14
Latch-valve Replacement Parts	15
□ Puritan-Bennett Compatible Outlets	
Latch-valve Service Instructions	16
Latch-valve Replacement Parts	17
□ Chemetron Compatible Outlets	
Latch-valve Service Instructions	18
Latch-valve Replacement Parts	19
□ “Back-Body Assemblies”	
Service Instructions	20
Replacement Parts	21
□ Optional Equipment	22

Product Description

A complete *Ohio Medical Corporation Medical Gas Outlet* is made up of two separate components, the “Back-Body Assembly” and the “Latch-Valve Mechanism”. The “Back-Body Assembly” is designed to be unique to each specific gas but is interchangeable within all “same-gas” outlet types (D.I.S.S., Ohmeda, Puritan-Bennett or Chemetron compatibles).

The gas specific “Back-Body Assembly” includes a check valve that permits removal of the “Latch-Valve Mechanism” for service without requiring the pipeline to be shut down.

A 6” long, 3/8” nom. dia. medical gas copper tube, per NFPA specifications, is brazed into the body for external pipeline connections. The “Back-Body Assembly” is marked with color-coded labeling on the front plate and on the copper pipe so that the installer can easily identify the correct gas when making the installation. The *Ohio Medical Corporation Medical Gas Outlet* is designed with a gas-specific dual pin indexing arrangement to prevent an incorrect gas “Latch-Valve Mechanism” from being installed into a “Back-Body Assembly”.

Ohio Medical Corporation Medical Gas Outlets (Wall and Ceiling styles only) may be ganged together in 5” [127mm] center to center assemblies providing one attractive module of all medical gases without the additional expense of a headwall or console.

It is the “Latch-Valve Mechanism” which determines which type of adapter that the completed outlet assembly will accept. The “Latch-Valve Mechanism” is available in four different offerings; D.I.S.S. Type, Quick-Connect Ohmeda Compatible, Puritan-Bennett Compatible and Quick-Connect Chemetron Compatible. The “Latch-Valve Mechanism” consists of a connector with an internal check valve, an indexing assembly and a color-coded gas specific front plate. A trim plate is also included for wall and ceiling outlets. The “Latch-Valve Mechanism” is designed and manufactured so that its gas specific characteristics cannot be altered during normal use, service or maintenance. The “Latch-Valve Mechanism” is inserted into the “Back-Body Assembly” and secured with plated steel screws to complete the outlet assembly.

The Quick-Connect models are compatible with Ohmeda Diamond, Puritan-Bennett or Chemetron Quick-Connect adapters and only the correct corresponding gas type of adapters can be used with the Quick-Connect outlets.

Since the “Back-Body Assembly” is the same for all types of “Latch-valve Mechanisms” of the same gas, the *Ohio Medical Corporation Medical Gas Outlets* can easily be converted from one adapter type to another by simply replacing the “Latch-Valve Mechanism”.

WALL OUTLETS

D.I.S.S. TYPE, OHMEDA COMPATIBLE, PURITAN-BENNETT COMPATIBLE AND CHEMETRON COMPATIBLE

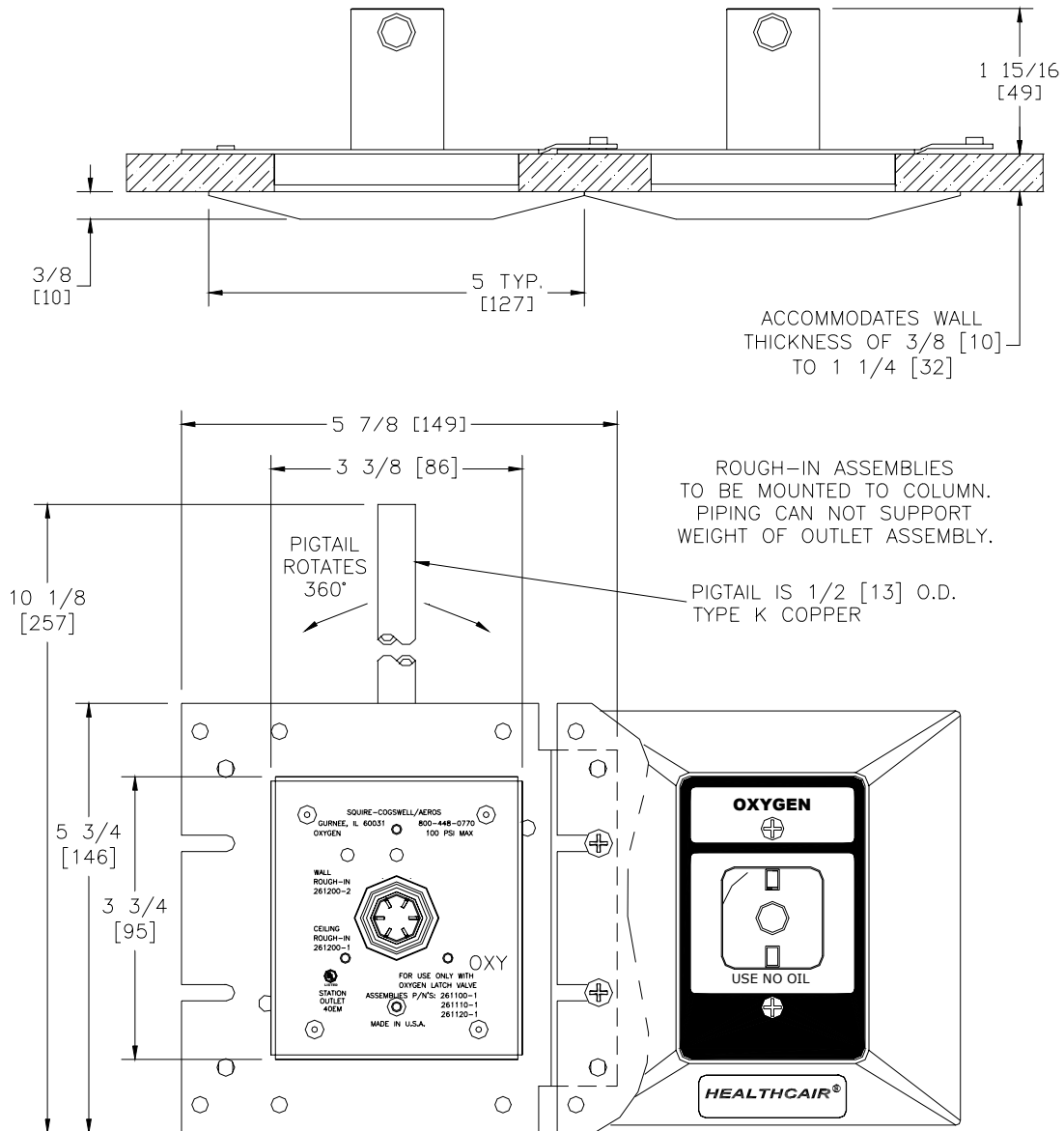

NOTES:

1. Do not cover over the Back-Body Assembly during the drywall and plaster application. Ensure that the clear plastic cover over the Back-Body Assembly is securely in place until the "Latch-Valve Mechanism" can be installed.
2. For W.A.G.D. (Evacuation) and vacuum gases, a round tubing plug and a plug retainer plate are installed on the Back-Body Assembly since a secondary check valve does not exist for these gases. Do not remove these components until the latch valve mechanism is to be installed.

CEILING OUTLETS D.I.S.S. TYPE

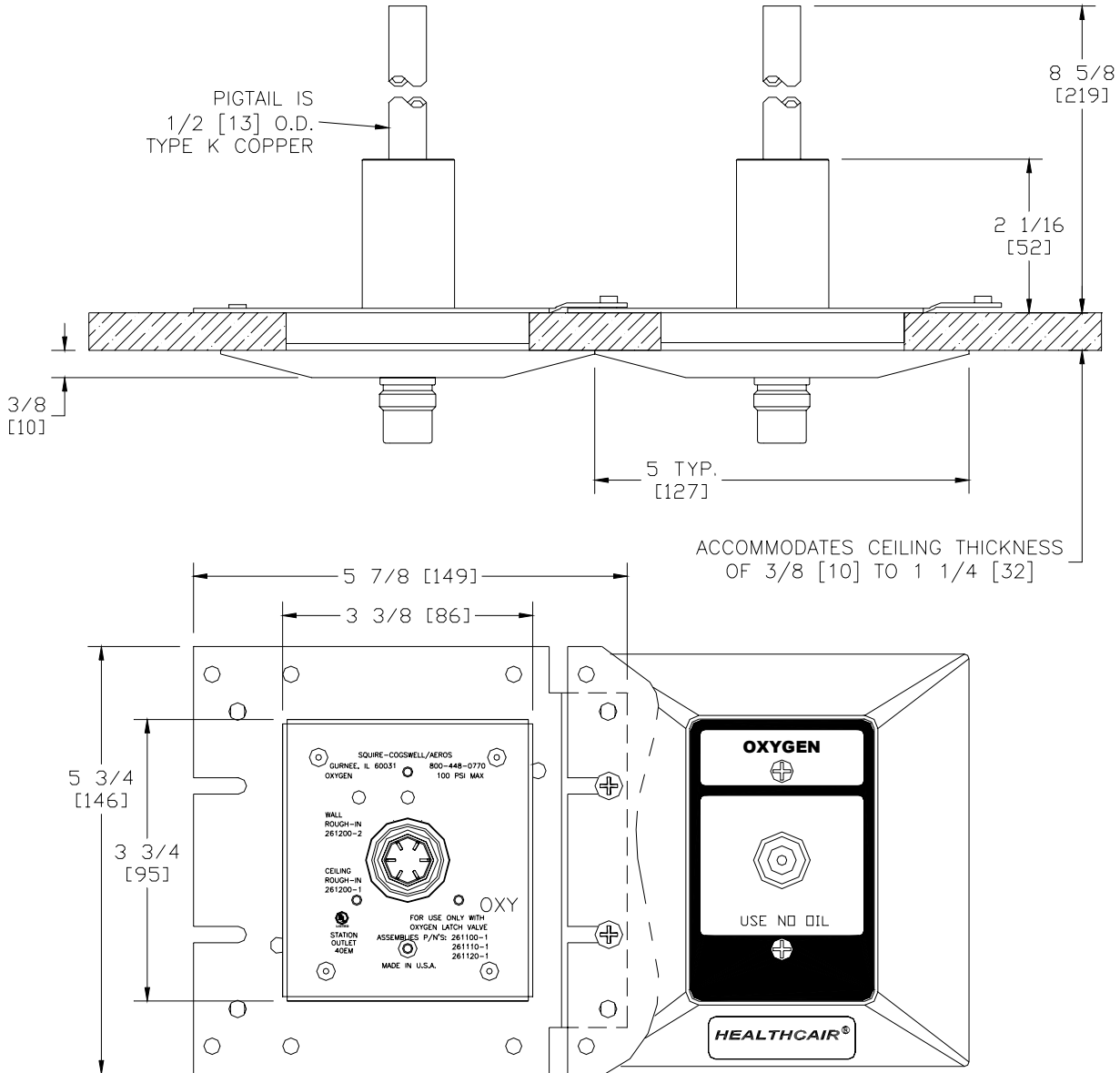

ROUGH-IN ASSEMBLIES TO BE MOUNTED TO COLUMN.
PIPING CAN NOT SUPPORT WEIGHT OF OUTLET ASSEMBLY.

NOTES:

1. Do not cover over the Back-Body Assembly during the drywall and plaster application. Ensure that the clear plastic cover over the Back-Body Assembly is securely in place until the "Latch-Valve Mechanism" can be installed.
2. For W.A.G.D. (Evacuation) and vacuum gases, a round tubing plug and a plug retainer plate are installed on the Back-Body Assembly since a secondary check valve does not exist for these gases. Do not remove these components until the latch valve mechanism is to be installed.

CONSOLE OUTLETS

D.I.S.S. TYPE, OHMEDA COMPATIBLE, PURITAN-BENNETT COMPATIBLE AND CHEMETRON COMPATIBLE

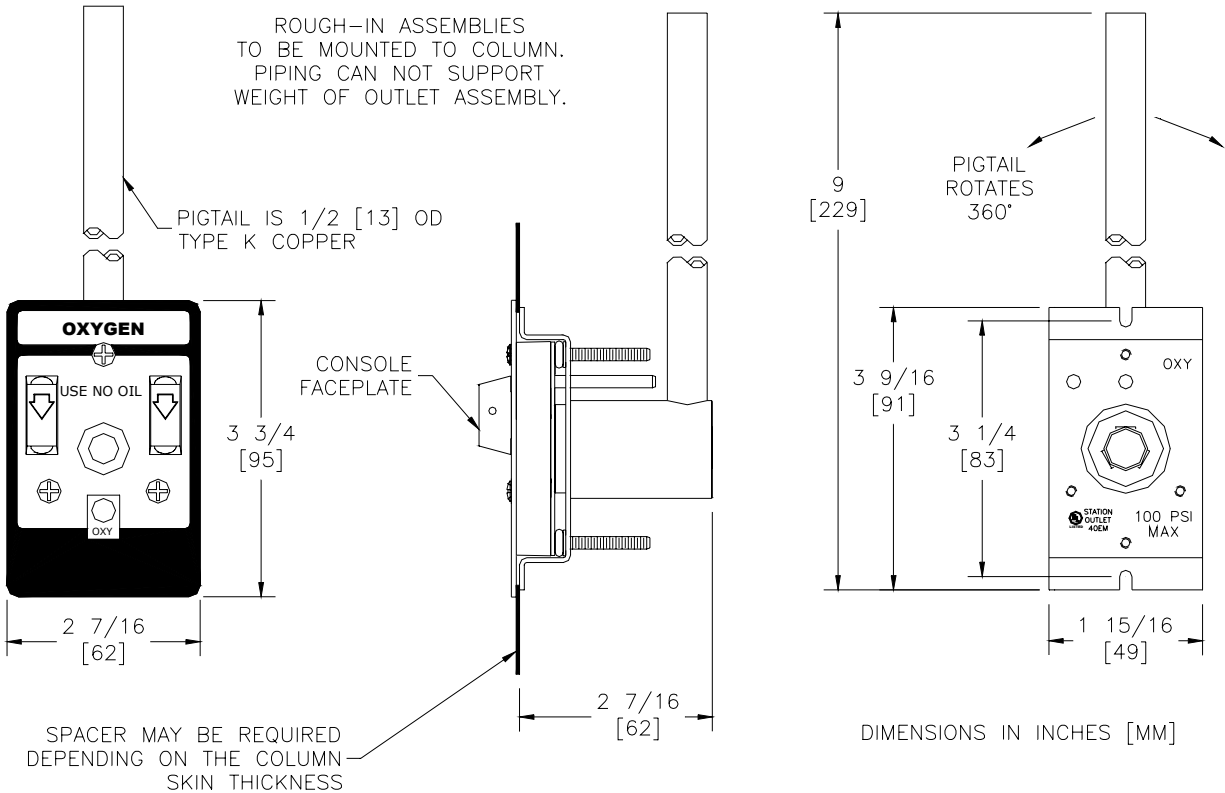

NOTES:

1. For W.A.G.D. (Evacuation) and vacuum gases, a round tubing plug and a plug retainer plate are installed on the Back-Body Assembly since a secondary check valve does not exist for these gases. Do not remove these components until the latch valve mechanism is to be installed.

CEILING COLUMN OUTLETS

D.I.S.S. TYPE, OHMEDA COMPATIBLE, PURITAN-BENNETT COMPATIBLE AND CHEMETRON COMPATIBLE

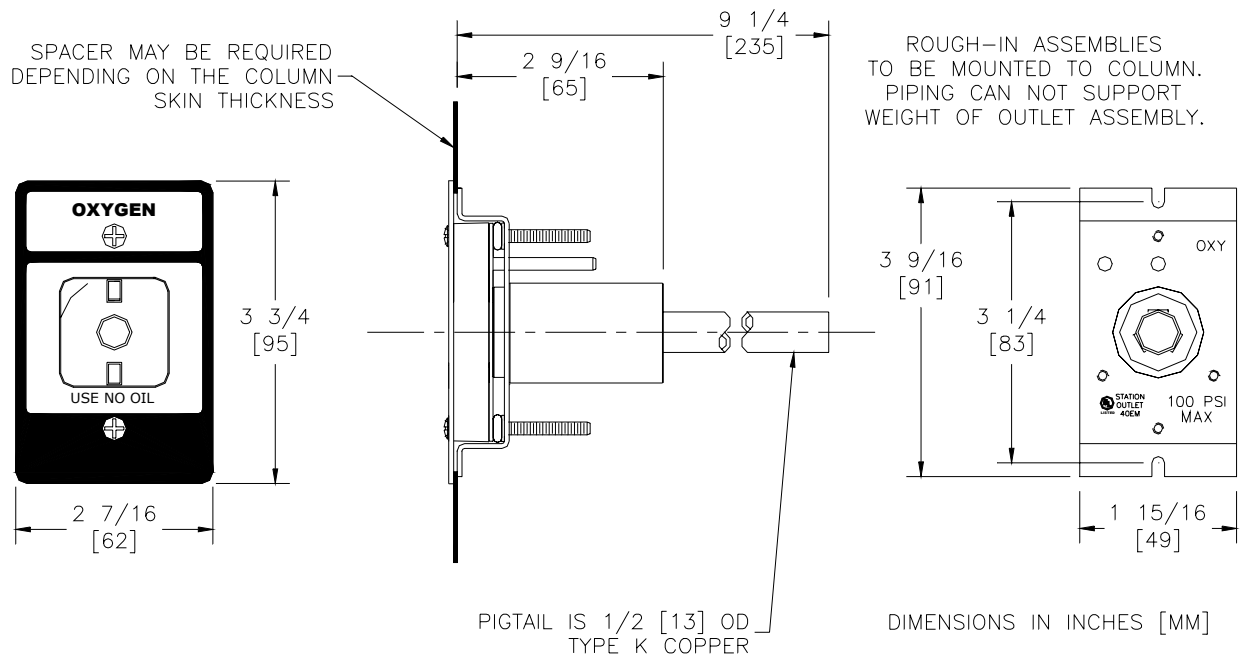

NOTES:

1. For W.A.G.D. (Evacuation) and vacuum gases, a round tubing plug and a plug retainer plate are installed on the Back-Body Assembly since a secondary check valve does not exist for these gases. Do not remove these components until the latch valve mechanism is to be installed.

MEDICAL GAS OUTLETS COMPLETE ASSEMBLY PART NUMBERS

OHMEDA COMPATIBLE OUTLET ASSEMBLIES

	<u>OXYGEN</u>	<u>VACUUM</u>	<u>N2O</u>	<u>MEDICAL AIR</u>	<u>NITROGEN</u>
WALL	261010-1	261010-5	261010-9	261010-13	N/A
CONSOLE	261010-2	261010-6	261010-10	261010-14	N/A
CEILING	261010-3	261010-7	261010-11	261010-15	N/A
CEILING COLUMN	261010-4	216010-8	261010-12	261010-16	N/A

PURITAN-BENNETT COMPATIBLE OUTLET ASSEMBLIES

	<u>OXYGEN</u>	<u>VACUUM</u>	<u>N2O</u>	<u>MEDICAL AIR</u>	<u>NITROGEN</u>
WALL	261040-1	261040-5	261040-9	261040-13	N/A
CONSOLE	261040-2	261040-6	261040-10	261040-14	N/A
CEILING	261040-3	261040-7	261040-11	261040-15	N/A
CEILING COLUMN	261040-4	216040-8	261040-12	261040-16	N/A

CHEMETRON COMPATIBLE OUTLET ASSEMBLIES

	<u>OXYGEN</u>	<u>VACUUM</u>	<u>N2O</u>	<u>MEDICAL AIR</u>	<u>NITROGEN</u>
WALL	261020-1	261020-5	261020-9	261020-13	N/A
CONSOLE	261020-2	261020-6	261020-10	261020-14	N/A
CEILING	261020-3	261020-7	261020-11	261020-15	N/A
CEILING COLUMN	261020-4	216020-8	261020-12	261020-16	N/A

D.I.S.S. OUTLET ASSEMBLIES

	<u>OXYGEN</u>	<u>VACUUM</u>	<u>N2O</u>	<u>MEDICAL AIR</u>	<u>NITROGEN</u>
WALL	261000-1	261000-5	261000-9	261000-13	261000-17
CONSOLE	261000-2	261000-6	261000-10	261000-14	261000-18
CEILING	261000-3	261000-7	261000-11	261000-15	261000-19
CEILING COLUMN	261000-4	216000-8	261000-12	261000-16	261000-20

LATCH-VALVE MECHANISM & BACK-BODY ASSEMBLY PART NUMBERS

“LATCH-VALVE MECHANISM”					
PART NUMBERS					
	<u>OXYGEN</u>	<u>VACUUM</u>	<u>N2O</u>	<u>MEDICAL AIR</u>	<u>NITROGEN</u>
D.I.S.S.	261100-1	261100-2	261100-3	261100-4	261100-5
OHMEDA COMPATIBLE	261110-1	261110-2	261110-3	261110-4	N/A
PURITAN-BENNETT COMPATIBLE	261140-1	261140-2	261140-3	261140-4	N/A
CHEMETRON COMPATIBLE	261120-1	261120-2	261120-3	261120-4	N/A

“BACK-BODY ASSEMBLY”					
PART NUMBERS					
	<u>OXYGEN</u>	<u>VACUUM</u>	<u>N2O</u>	<u>MEDICAL AIR</u>	<u>NITROGEN</u>
WALL	261200-2	261200-4	261200-6	261200-8	261200-10
CEILING	261200-1	261200-3	261200-5	261200-7	261200-9
CONSOLE	261210-2	261210-4	261210-6	261210-8	261210-10
CEILING COLUMN	261210-1	216210-3	261210-5	261210-7	261210-9

INSTALLATION NOTES

- On all wall and console outlets the connecting pipe can be rotated a full 360 degrees for ease of connection to the facility gas piping.
- Excessive heat during soldering may damage the secondary check valve; when soldering the pipe connection take extreme care not to apply heat to the check unit body.
- When installing wall outlets, it is very important to keep the plastic protective cover on the “Back-Body Assembly” in place during construction, to protect the outlet from drywall compound or other contaminants.
- For W.A.G.D. (Evacuation) and vacuum gases, a round tubing plug and a plug retainer plate are installed on the Back-Body Assembly since a secondary check valve does not exist for these gases. Do not remove these components until the latch valve mechanism is to be installed.
- When installing the “Latch-Valve Mechanism”, remove the protective cover from the “Back-Body Assembly” and inspect for dirt or debris in the outlet body. Carefully clean out any contaminants as necessary.
- The “Latch-Valve Mechanism” should slide smoothly into the “Back-Body Assembly”. If it does not, inspect to verify that there has been no damage to the indexing pins. If the indexing pins are bent or damaged the gas specific characteristics of the outlet may be compromised. In this instance the entire “Latch-Valve Mechanism” should be replaced.
- All “Latch-Valve Mechanisms” with the exception of Nitrogen D.I.S.S. have a Maximum pressure rating of 100 PSI [690 kPa]. The Nitrogen D.I.S.S. Latch-Valve Mechanism has a maximum pressure rating of 200 psi [1,380 kPa].
- After the installation medical gas pipeline systems should be tested in accordance with NFPA recommendations and/or in compliance with local requirements.
- The “Back-Body Assemblies” may be pressure tested up to a maximum of 200 psi [1,380 kPa] without the “Latch-Valve Mechanism” installed. **DO NOT PRESSURE TEST THE PIPELINE OVER 100 PSI [690 kPa] IF THE “LATCH VALVE MECHANISM” HAS BEEN INSTALLED.**

SERVICING CAUTIONS

Before performing any service or maintenance on any outlet, the appropriate hospital maintenance or engineering personnel should be notified.

The “Latch-Valve Mechanism” can be removed without interrupting service to other outlets on the same pipeline for all gases other than vacuum, however when servicing the “Back-Body Assembly” the supply pressure must be shut off to the entire zone.

SERVICING INSTRUCTIONS D.I.S.S. TYPE “LATCH-VALVE MECHANISM”

1. Unscrew the two retaining screws (**I**) until the “Latch-Valve Mechanism” can be removed from the outlet.
2. Remove the Adapter O-Ring seal (**A, B or C**) from the front and replace (NOTE: There is no O-Ring for Oxygen or Evac).
3. Remove the retaining ring (**E**) using the appropriate internal snap ring pliers.
4. Remove the valve stem (**G**), Primary Check O-Ring (**H**), primary check valve (**D**) and check valve spring (**F**). Inspect the items for wear or damage and replace if needed. Replace the O-Ring.
5. Reinstall all internal components and lock in place with the retaining ring.
6. Reinstall the “Latch-Valve Mechanism” into the outlet. Coat the valve body, with a thin coat of oxygen compatible silicone lubricant to aid insertion. Tighten down the retaining screws, DO NOT OVER TIGHTEN, as this could damage the Latch-valve.
7. Connect the proper gas specific adapter to the outlet. The connection should be smooth and hand tightening of the nut should be sufficient to allow the gas to flow without leakage.

CAUTION: Use caution relative to the type and pressure of the gas so as not to cause injury.

8. If the assembly does not perform correctly with the adapter installed, replace the entire “Latch-Valve Mechanism”.

REPLACEMENT PARTS LATCH-VALVE MECHANISMS - D.I.S.S. TYPE OUTLETS

<i>ITEM</i>	<i>DESCRIPTION</i>	<i>PART NUMBER</i>
A	Adapter O-ring - Vac	261404
B	Adapter O-ring - N2O	261403
C	Adapter O-ring - Air/N2,CO2	261405
D	Primary Check Valve	261323
E	Retaining Ring	261422
F	Check Valve Spring	263268
G	Valve Stem (Oxygen)	261325
(not shown)	Valve Stem (Vac,Evac)	261326
(not shown)	Valve Stem (Air, N2O,N2,CO2)	261324
H	Primary Check Valve O-ring	261403
I	Retaining Screw (2 req'd)	261413
J	Screw Retaining O-ring (2 req'd)	261401

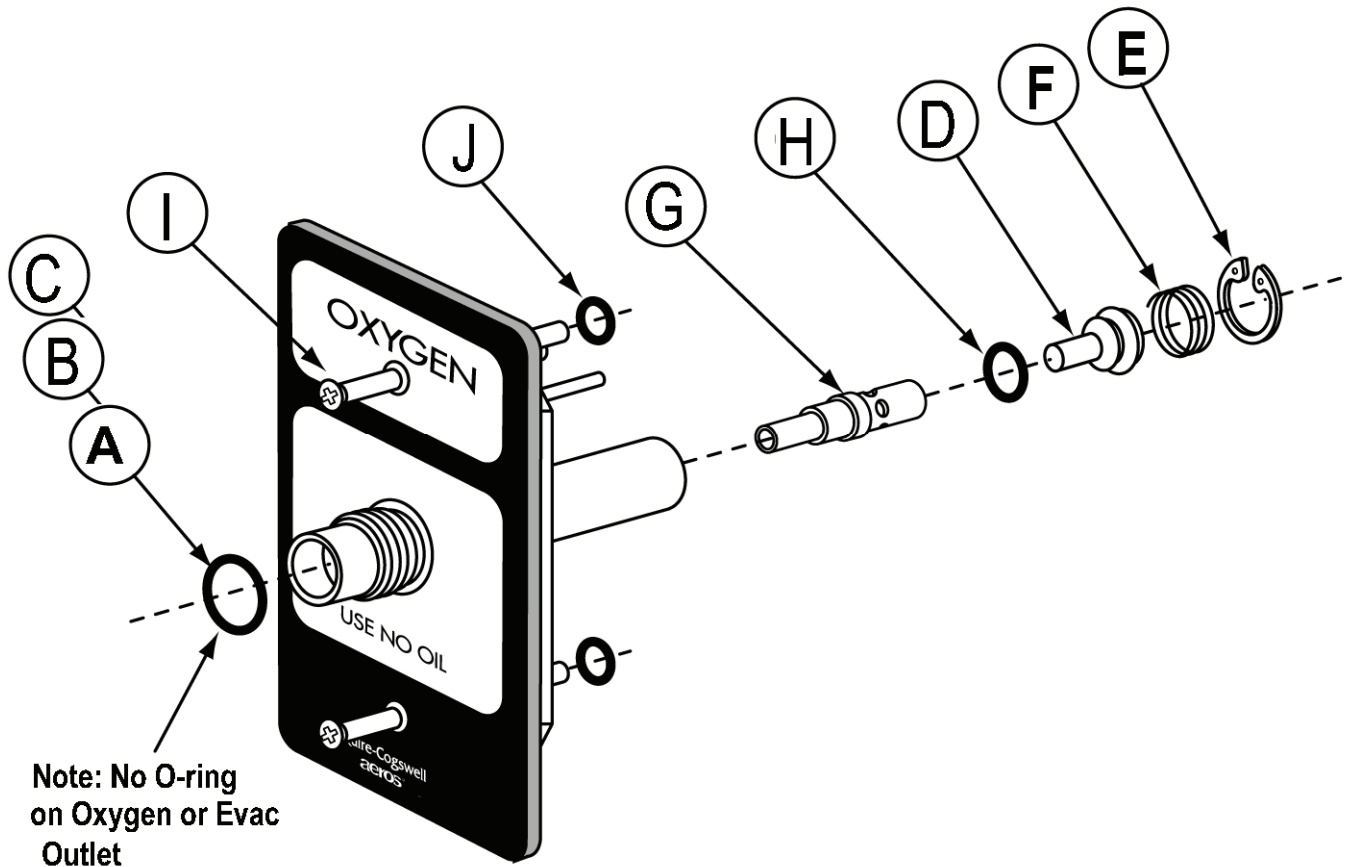

SERVICING INSTRUCTIONS OHMEDA COMPATIBLE “LATCH-VALVE MECHANISM”

1. Unscrew the two retaining screws (**L**) until the entire “Latch-Valve Mechanism” can be removed from the outlet.
2. Remove the four screws (**O**) holding the connector retaining plate (**A**) in place. Remove the plate.
3. Remove the valve body (**B**) from the valve assembly.
4. Remove the U-spring (**N**), inspect for wear or damage, reinstall or replace the U-spring as necessary.
5. Remove the flat washer (**I**) and valve body O-Ring (**J**) from the front of the valve body. Inspect the items for wear or damage and replace the O-Ring seal (**J**).
6. Remove the retaining ring (**F**) using appropriate snap ring pliers. Remove the primary cap (**K**), primary cap spring (**C**), primary check valve O-Ring (**D**), primary check valve (**E**) and spring (**H**). Inspect all items for wear or damage and replace as necessary. Replace the O-Ring (**D**).
7. Reinstall all internal components and lock in place with retaining ring (**F**). Insert the valve body (**B**) into the latch valve body. Check that the U-Spring (**N**), flat washer (**I**) and valve body O-Ring (**J**) are in place. Reinstall the retaining plate (**A**) and secure with four screws (**O**), do not over tighten.
8. Reinstall the “Latch-Valve Mechanism” into the outlet. Coat the valve body (**B**), with a thin coat of oxygen compatible silicone lubricant to aid insertion. Tighten down the retaining screws (**L**), DO NOT OVER TIGHTEN, as this could damage the Latch-valve.
9. Connect the proper gas specific adapter into the outlet. The connection should be smooth and the adapter should lock and remain in place allowing gas to flow.

CAUTION: Use caution relative to the type and pressure of the gas so as not to cause injury.

10. If the assembly does not perform correctly with the adapter installed, replace the entire “Latch-Valve Mechanism”.

REPLACEMENT PARTS LATCH-VALVE MECHANISMS - OHMEDA COMPATIBLE OUTLETS

<i>ITEM</i>	<i>DESCRIPTION</i>	<i>PART NUMBER</i>
A	Plate	261335
B	Valve Body	261318
C	Primary Cap Spring	261409
D	Check Valve O-ring	261403
E	Primary Check Valve	261323
F	Retaining Ring	261422
G	Screw (4 req'd)	261429
H	Check Valve Spring	263268
I	Flat Washer	261415
J	Valve Body O-ring	261402
K	Primary Cap	261311
L	Screw (2 req'd)	261413
M	Screw Retaining O-ring	261401
N	U-spring	261406

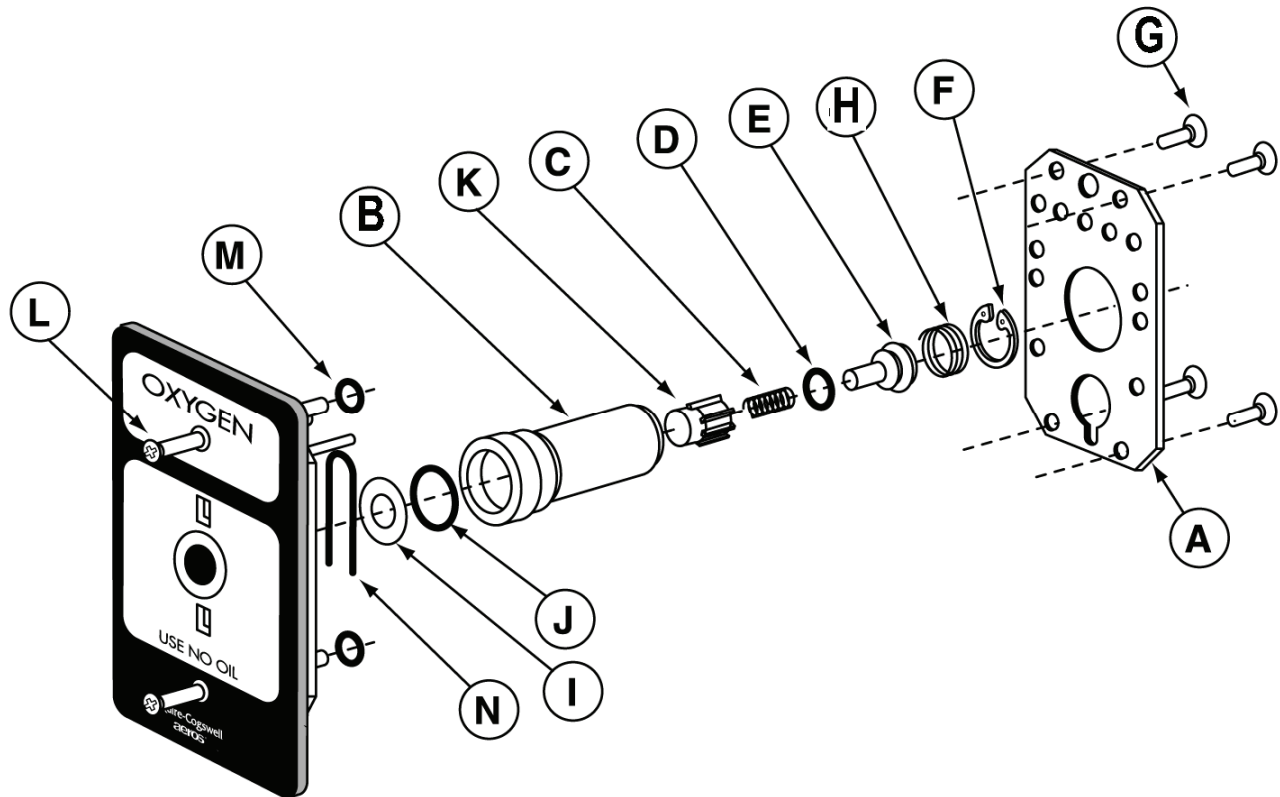

SERVICING INSTRUCTIONS PURITAN-BENNETT COMPATIBLE “LATCH-VALVE MECHANISM”

1. Unscrew the two mounting screws (9) until the entire “Latch-Valve Mechanism” can be removed from the outlet.
2. Remove the two screws (8) holding the retaining ring (7) in place. Remove the retaining ring.
3. Remove the connector (6) from the valve assembly.
4. Remove the seal ring (3), check valve (4), and valve spring (5) from connector (6). Inspect all items for wear or damage and replace.
5. Reinstall all internal components and lock in place with seal ring (3). Insert the connector body (6) onto the latch valve body (1). Reinstall retaining ring (7) and secure with two screws (8).
6. Reinstall the “Latch-Valve Mechanism” into the outlet. Coat the connector (6) with a thin coat of oxygen compatible silicone lubricant to aid insertion. Tighten down the mounting screws (9), DO NOT OVER THIGHTEN, as this could damage the Latch-valve.
7. Connect the proper gas specific adapter into the outlet. The connection should be smooth and the adapter should lock and remain in place allowing gas to flow.

CAUTION: Use caution relative to the type and pressure of the gas so as not to cause injury.

8. If the assembly does not perform correctly with the adapter installed, replace the entire “Latch-Valve Mechanism”.

REPLACEMENT PARTS

LATCH-VALVE MECHANISMS - PURITAN-BENNETT COMPATIBLE OUTLETS

<i>ITEM</i>	<i>DESCRIPTION</i>	<i>PART NUMBER</i>
3	Seal Ring	
4	Check Valve	
5	Valve Spring	
6	Connector	
7	Retaining Ring	
8	Screws	
9	Mounting Screw	
2	Mounting Screw O-ring	
1	Panel Assembly, Oxygen	
1	Panel Assembly, Vacuum	
1	Panel Assembly, Medical Air	
1	Panel Assembly, N2O	
1	Panel Assembly, WAGD	

Seal Ring (#3)
 Check Valve (#4)
 Valve Spring (#5)

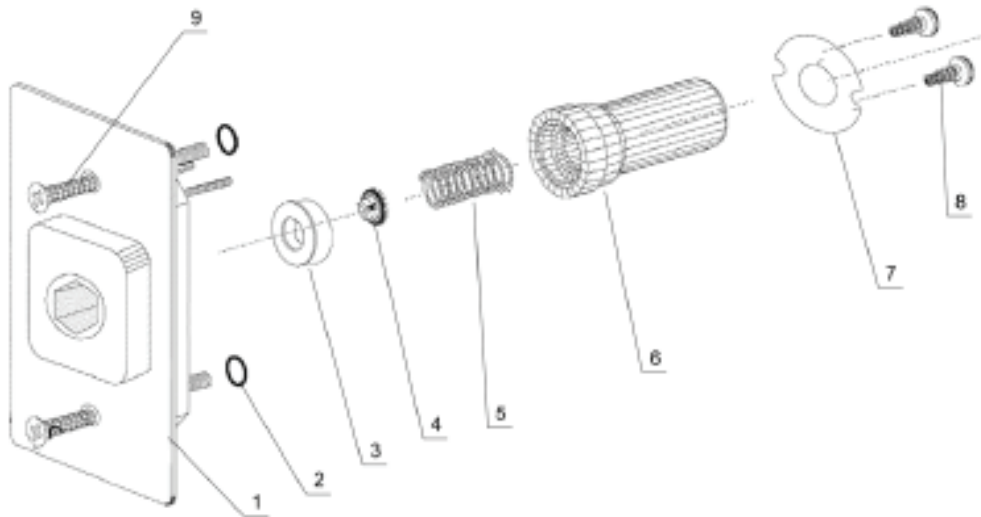

SERVICING INSTRUCTIONS CHEMETRON COMPATIBLE “LATCH-VALVE MECHANISM”

1. Unscrew the three retaining screws **(M)** until the entire “Latch-Valve Mechanism” can be removed from the outlet.
2. Remove the four screws **(N)** holding the connector retaining plate **(A or B)** in place. Remove the plate.
3. Remove the valve body **(G)** from the valve assembly.
4. Remove the flat washer **(I)** and valve body O-Ring **(J)** from the front of the valve body. Inspect the items for wear or damage and replace the O-Ring seal **(J)**.
5. Remove the retaining ring **(F)** using appropriate snap ring pliers. Remove the primary cap **(K)**, primary cap spring **(C)**, O-Ring seal **(D)**, primary check valve **(E)** and spring **(H)**. Inspect all items for wear or damage and replace as necessary. Replace the O-Ring **(D)**.
6. Reinstall all internal components and lock in place with retaining ring **(F)**. Insert the valve body **(G)** into the latch valve body. Check that the flat washer **(I)** and O-Ring **(J)** are in place. Reinstall the connector retaining plate **(A or B)** and secure with four screws **(N)**, do not over tighten.
7. Reinstall the “Latch-Valve Mechanism” into the outlet. Coat the valve body **(G)**, with a thin coat of oxygen compatible silicone lubricant to aid insertion. Tighten down the retaining screws **(M)**, DO NOT OVER TIGHTEN, as this could damage the Latch-valve.
8. Connect a gas specific adapter into the outlet. The connection should be smooth and the adapter should lock and remain in place allowing gas to flow.

CAUTION: Use caution relative to the type and pressure of the gas so as not to cause injury.

9. If the assembly does not perform correctly with the adapter installed, replace the entire “Latch-Valve Mechanism”.

REPLACEMENT PARTS LATCH-VALVE MECHANISMS - CHEMETRON COMPATIBLE OUTLETS

<i>ITEM</i>	<i>DESCRIPTION</i>	<i>PART NUMBER</i>
A	Plate – All Gases except Evac	261335
B	Plate – Evac	261462
C	Primary Cap Spring	261409
D	Check Valve O-ring	261403
E	Primary Check Valve	261323
F	Retaining Ring	261422
G	Valve Body	261318
H	Check Valve Spring	263268
I	Flat Washer	261415
J	Valve Body O-ring	261402
K	Primary Cap	261311
L	Screw Retaining O-ring	261401
M	Screw (3 req'd)	261413
N	Screw (4 req'd)	261429

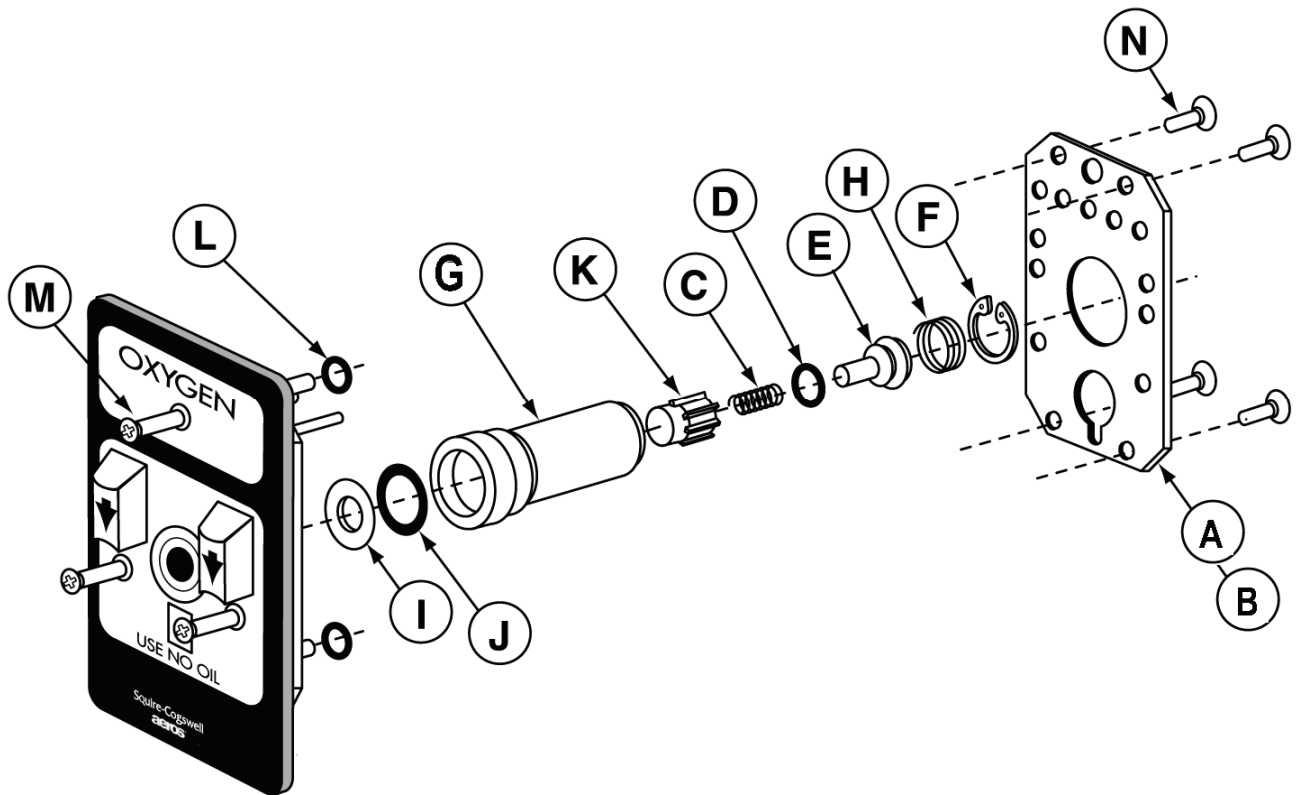

SERVICING INSTRUCTIONS “BACK-BODY ASSEMBLY” - ALL OUTLETS

Inside the “Back-Body Assembly” is a secondary check valve that performs the function of shutting off the gas flow for all pressurized gases when the “Latch-Valve Mechanism” is removed. This seat/seal also prevents leaks around the latch-valve connector.

Back-Body Assemblies for vacuum and evacuation gases do not contain a secondary check valve. If it becomes necessary to remove the Latch Valve mechanism from these outlets for service, the Back-Body Assembly must be plugged with a 3/4" round tubing plug (or equivalent) to prevent excessive draw on the vacuum pump.

The secondary seal will rarely need replacement. However, if the seat/seal does need replacement follow the following procedure:

CAUTION: Ensure that the supply pressure is shut off before performing maintenance on the “Back-Body Assembly”.

1. **Ensure that no pressure exists in the assembly or pipeline by depressing the secondary check valve (C) until all gas pressure has been relieved from isolated piping zone. Nitrous Oxide and Carbon Dioxide must not be vented near staff or patients.**
2. Remove the retaining ring (D) from the inside of the outlet body.
3. Remove the washer (E), seat/seal (F), secondary check valve *(C) and secondary check valve spring *(B). Inspect all items for wear or damage and replace the seat/seal (F); replace other components as necessary.
4. Reinstall the spring *(B), secondary check valve *(C), seat/seal (F) and the washer (E). Insert the retaining ring (D) into the slot and ensure that the ring is seated properly.
5. Carefully restore pressure to the pipeline and check for leaks.
6. Reinstall the “Latch-Valve Mechanism” and perform appropriate inspection and testing as recommended by NFPA and local requirements.

REPLACEMENT PARTS “BACK-BODY ASSEMBLY” – ALL OUTLETS

<i>ITEM</i>	<i>DESCRIPTION</i>	<i>PART NUMBER</i>
A	Screw-Wall outlet (2)	261412
B	Secondary Check valve spring	261407*
C	Secondary Check valve	261309*
D	Retaining Ring	261421
E	Washer	261414
F	Seat/Seal	261360

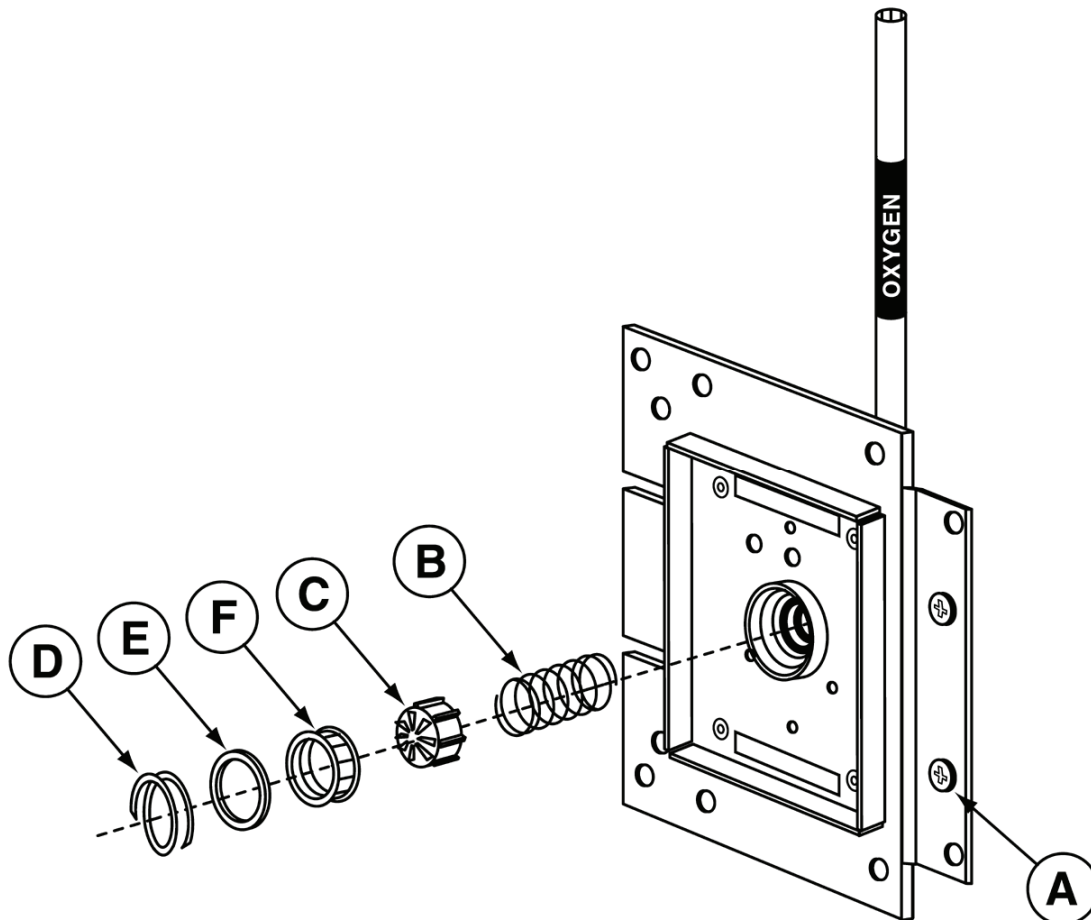

OPTIONAL EQUIPMENT:

Ohmeda Locking Device

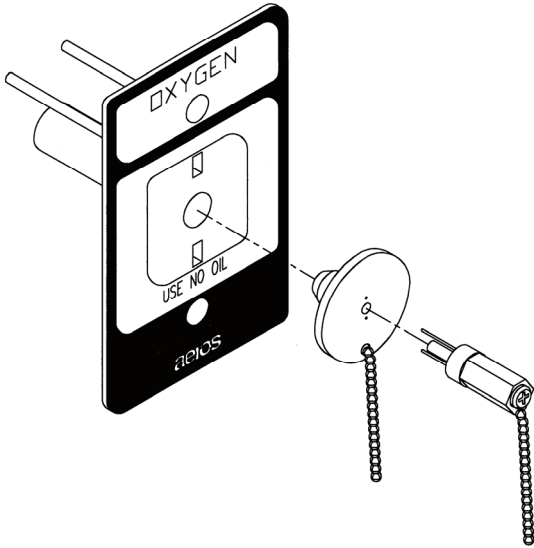

The locking kit shall prevent tampering of the internal primary check valve, located in the latch valve assembly.

The locking kit consists of a chrome plated locking cap which plugs into the Ohmeda outlet. Inserting and turning the key will pop off the lock and allow flow of the gas.

Part Numbers:

261639 Ohmeda Locking Kit
(all gases)

261640 Key for Ohmeda Locking Kit

DISS Locking Device

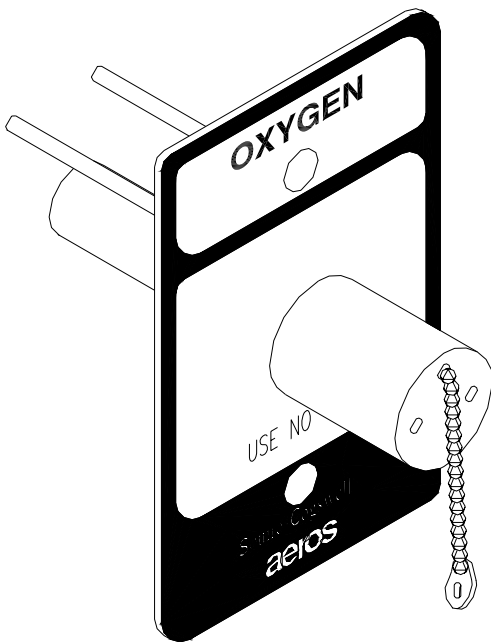

The locking kit shall prevent tampering of the internal primary check valve, located in the latch valve assembly.

The locking kit consists of a chrome plated threaded cap which screws into the DISS outlet. Inserting and turning the key will unlock the medical gas outlet and allow flow of the gas.

Part Numbers:

261637 DISS Locking Kit (all gases except
Oxygen and Evac)

261638 DISS Locking Kit for Oxygen

263262 Key

NOTES:

For 24/7 Technical Support, call 847-855-6234 for assistance.

OHIO MEDICAL CORPORATION

1111 Lakeside Drive
Gurnee, IL 60031-4099

Phone: 800-448-0770 or 847-855-0500

Fax: 847-855-6300

Email: info@ohiomedical.com

<http://www.ohiomedical.com>

P/N 255084 (Rev.9) 05/2007

